

Defensive Barrier

Effective & Economical Defense Solution



CONTENTS

• Company Profile |-----• 02

• Product Overview |-----• 04

• Main Structures |-----• 05

• Standardized & Skilled production |-----• 07

• Assembly Guidance |-----• 08

• Applications |-----• 09

• Projects Reference List |-----• 10

Company Profile



HEBEI TUO FANG METAL PRODUCT FACTORY is a professional gabion meshes supplier in China. We are professionally engaged in the production and export of all kinds of woven and welded gabions for defense and decoration.

Our company has owned all kinds of weaving and welding machines of over 160 sets and more than 100 staff members ensure high production efficiency and low production loss. More than 20 research and development department workers have been developing more products suitable for customers' requirements and market trends.

Our new products DEFENSIVE BARRIERS, effective and economical measurements in military sites, peacekeeping and important base to supply protection for personnel, vehicles, facilities and equipment. They are regarded as the most significant development in field fortifications since the second World War.

MORE PRODUCTS...

Protection Use. Woven or welded gabions as gabion mattress and gabion boxes for flood, storm defense and river channel, river bank protections, as well as slope protection and noise barrier.

Decoration Use. Gabion planters and various furniture and decorations in private, commercial and other places can not only are used as functional facilities but also decorate the surrounding environments.



Slope Protection



Noise Barrier



River Bank Protection



River Channel Protection



Office Building Feature Wall



Gabion Planter



Waterfall Ways



Street Bench

Product Overview

DEFENSIVE BARRIERS are regarded as the most significant development in field fortifications since the second World War. They are effective and economical structures to protect safe of soldiers, vehicles, equipment and facilities in military sites, peacekeeping, humanitarian and civilian operations.

Defensive barriers are strong structures which are composed of welded gabions and non-woven polypropylene geotextile. According to different use environments, the defensive barriers can be made into standard and recoverable types for your choice.



Standard
Defensive
Barrier



Recoverable
Defensive
Barrier

- **Material:** hot-dipped galvanized steel wire or zinc-aluminum alloy steel wires.
- **Wire diameter:** 4 mm or 5 mm.
- **Mesh size:** 50 × 50 mm, 75 × 75 mm, 76.2 × 76.2 mm, 50 × 100 mm, 100 × 100 mm, ect.
- **Geotextile:** 2 mm heavy duty non-woven polypropylene.
- **Geotextile color:** White, beige, Military Green and other customized colors.



Beige (Most Popular)



Military Green

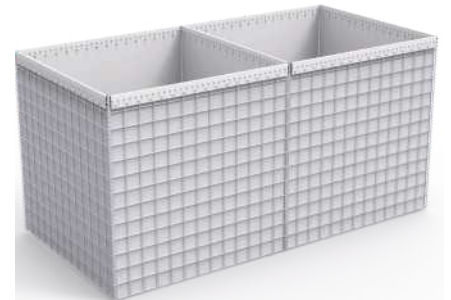

White

Main Structures

The **Defensive barriers** are available in various specifications and configurations for complex environments. Here are standard and popular types and specifications in the following.

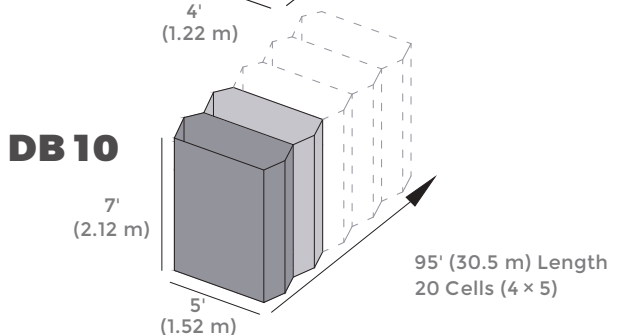
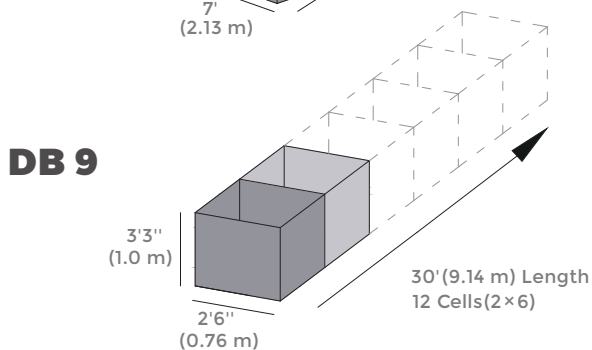
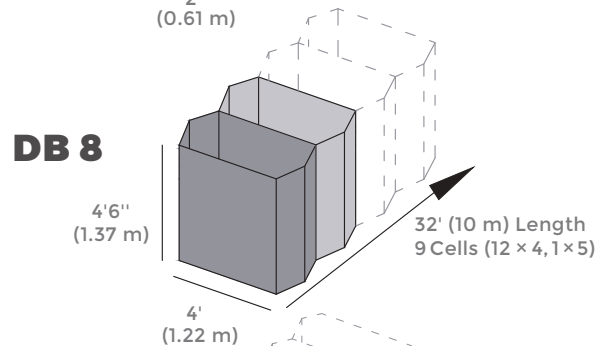
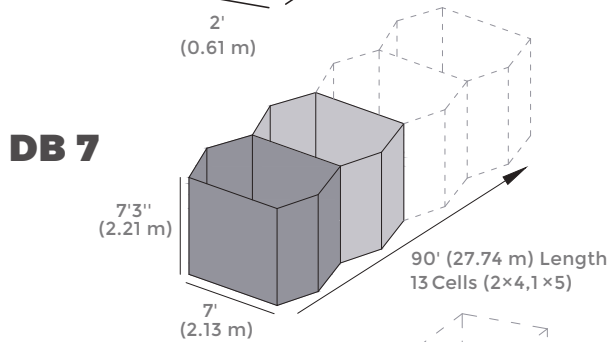
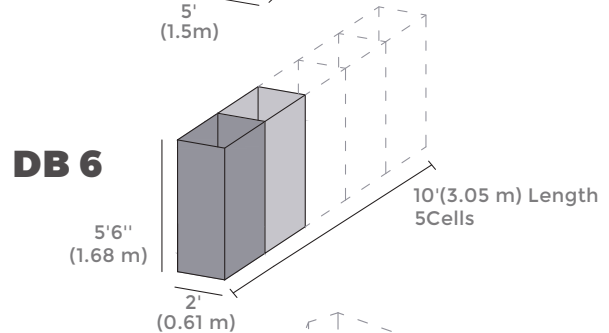
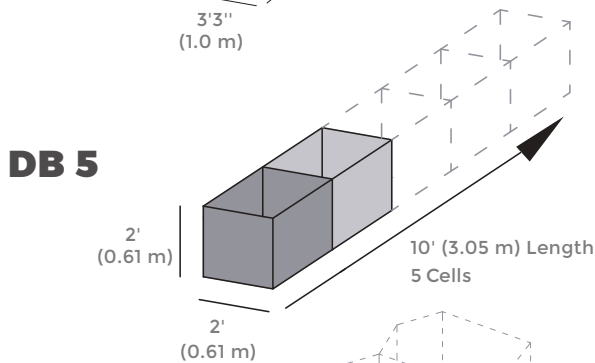
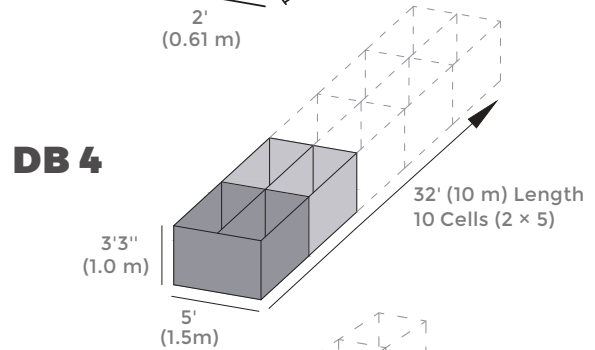
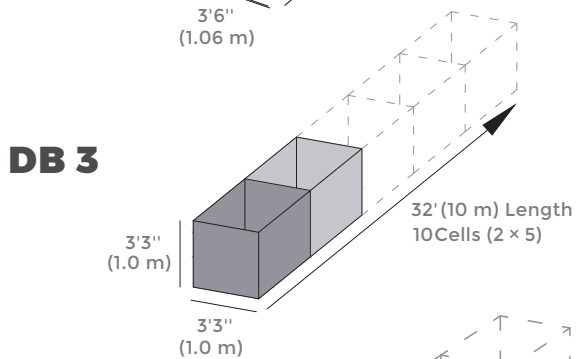
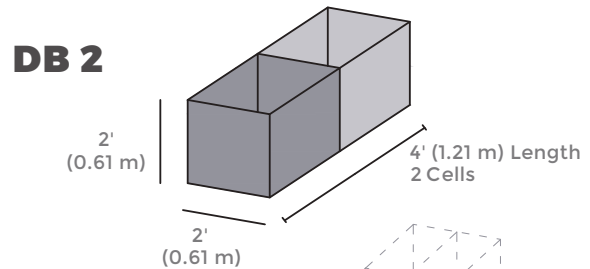
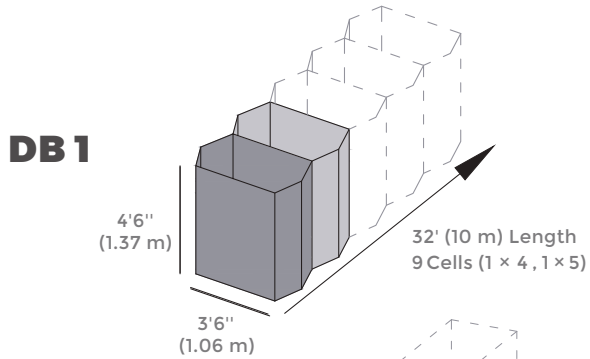

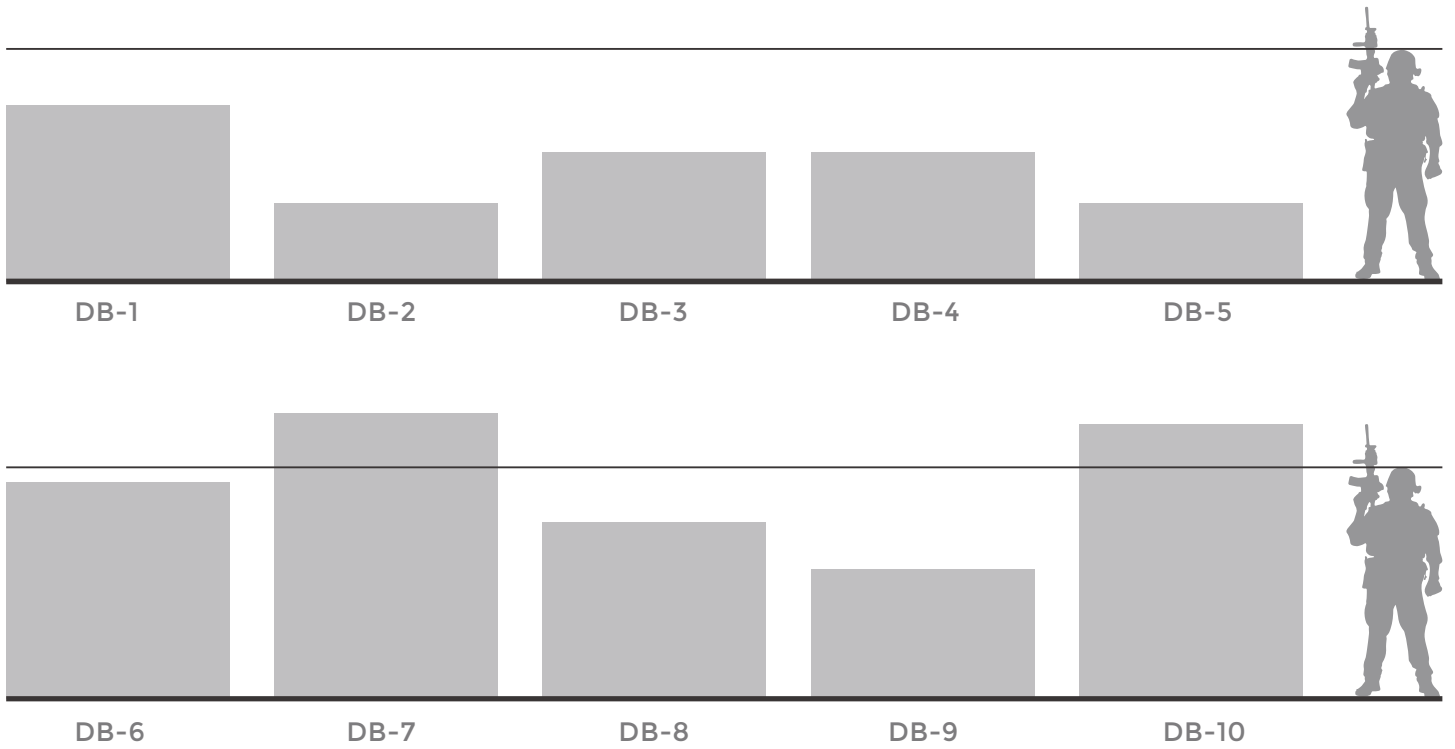

Common Specs of Defensive Barriers

Item	Height		Width		Length		Cell
	inch	m	inch	m	inch	m	
DB-1	4'6"	1.37	3'6"	1.06	32'	10	9 (1 × 4, 1 × 5)
DB-2	2'	0.61	2'	0.61	4'	1.21	2
DB-3	3'3"	1	3'3"	1	32'	10	10 (2 × 5)
DB-4	3'3"	1	5'	1.5	32'	10	10 (2 × 5)
DB-5	2'	0.61	2'	0.61	10'	3.05	5
DB-6	5'6"	1.68	2'	0.61	10'	3.05	5
DB-7	7'3"	2.21	7'	2.13	90'	27.74	13 (2 × 4, 1 × 5)
DB-8	4'6"	1.37	4'	1.22	32'	10	9 (1 × 4, 1 × 5)
DB-9	3'3"	1	2'6"	0.76	30'	9.14	12 (2 × 6)
DB-10	7'	2.13	5'	1.52	95'	30.5	20 (4 × 5)

Standardized & Skilled production

- **All Raw materials conform to international standards.**
 - All wires Wire tensile strength conforms to **BS 1052.**
 - Galvanized wire coating conforms to **ASTM A 641** and **EN 10244-2.**
 - Zinc-aluminum alloy wire coating conforms to **ASTM A 856.**
 - Geotextile conforms to **ISO 10319.**
- **Advanced equipment ensures accurate welding and specifications.**
- **Skilled workers reduce production loss and ensure timely delivery.**

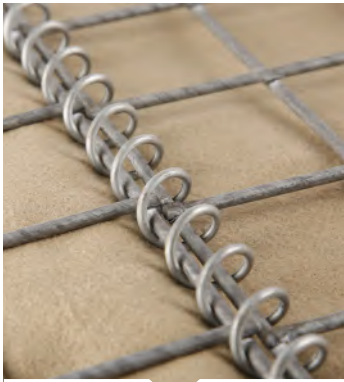

High Quality Raw material for durable life



Solid welds and smooth panel for safe and convenient use



High strength, penetration resistance geotextile



Skilled workers for fast assembly and timely delivery



Spring Wire Test



Welded Wire Test



Mesh Aperture Test



Overall Length Test

Assembly Guidance



Unpack



Pull Out and Set Up



Connect Together

01



02



03



Fill and Compact



Inspection and Adjustment



Final Projects

04



05



06

Applications

- Ammo compounds
- Noise abatement barriers
- Sentry towers
- Guard posts, both improvised and in kit form
- Vehicle barriers
- Entry Control Points
- Blast mitigation walls
- Cover from view
- Protection from ballistics
- Protection for aircraft (revetments)
- Protection of adjacent occupants from the accidental discharge of aircraft weapons
- Protection of living accommodations
- Provision of bomb shelters
- Asset protection



Sentry Tower Protection



Aircraft Protection



Living Accommodations Protection



Guard Post Protection















Personnel Safe Protection



Vehicle Protection

Projects Reference List

Project Information	Overview	
Cango Military 2,000 Line Meters Defense Barrier		
Iraq Military 3,000 Line Meters Defense Barrier		
Australia Private Construction 280 Units Safety Gabion Wall		
France Port Construction 1000 Unit Gabion Retaining Wall		
USA Landscape Construction 1000 Units Gabion planters		
Indonesia Coastal Protection 3500 Line Meter Flood Barrier		

Factory Address: Anping county, Hebei, 053600 China
Office: shiji huamao building, tiyu street, shijiazhuang city, hebei, china

Call US

Mob: +86 15075129626 (wechat&whats app)
+86 17303311319 (wechat&whats app)
+86 15333383021 (wechat&whats app)
+86 15333383093 (wechat&whats app)
+86 13739781300 (wechat&whats app)

Email:

lvy@tuofangfencing.com
info@tuofangfencing.com
sales01@tuofangfencing.com
sales02@tuofangfencing.com
sales03@tuofangfencing.com